

Technical Information

iTEMP[®] HART[®] TMT182

Temperature head transmitter

Head transmitter for resistance thermometers (RTD), thermocouples (TC), resistance and voltage transmitters (mV), HART[®] -protocol, for installation in a sensor head Form B

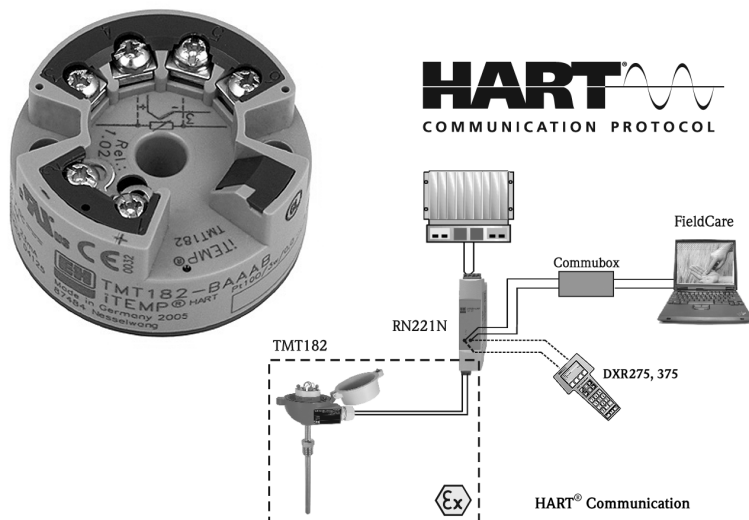

Application

- Temperature head transmitter with HART[®] -protocol for converting various input signals into an scalable 4 to 20 mA analog output signal
- Input:
 - Resistance thermometer (RTD)
 - Thermocouple (TC)
 - Resistance transmitter (Ω)
 - Voltage transmitter (mV)
- HART[®] -protocol for front end unit or panel unit operation using the hand operating module (DXR275, DXR375) or PC (e. g. ReadWin[®] 2000 or FieldCare)

Your benefits

- Universal settings with HART[®] -protocol for various input signals
- Operation, visualisation and maintenance via PC, e. g. FieldCare operating software
- 2 wire technology, 4 to 20 mA analog output
- High accuracy in total ambient temperature range
- Fault signal on sensor break or short circuit, presettable to NAMUR NE 43
- EMC to NAMUR NE 21, CE
- UL recognized component to UL 3111-1
- GL Germanischer Lloyd marine approval

- CSA General Purpose
- Ex-Certification
 - ATEX Ex ia and dust zone 22 in compliance with EN 50281-1
 - FM IS
 - CSA IS
- SIL2 compliant
- Galvanic isolation
- Output simulation
- Min./max. process value indicator function
- Customer specific linearization
- Linearization curve match
- Customer specific measurement range settings or expanded SETUP (see Questionnaire, → Page 8)



Function and system design

Measuring principle Electronic monitoring and conversion of input signals in industrial temperature measurement.

Measuring system The iTEMP® HART® TMT182 temperature head transmitter is a 2-wire transmitter with analog output. It has measurement input for resistance thermometers (RTD) in 2-, 3- or 4-wire connection, thermocouples and voltage transmitters. Setting up of the TMT182 is done using the HART® -Protocol with hand operating module (DXR275, DXR375) or PC (e.g. configuration software ReadWin® 2000 or FieldCare).

Input

Measured variable Temperature (temperature linear transmission behaviour), resistance and voltage

Measuring range Depending upon the sensor connection and input signal. The transmitter evaluates a number of different measurement ranges.

Type of input

	Type	Measurement ranges	Min. measurement range
<i>Resistance thermometer (RTD)</i>	Pt100 Pt500 Pt1000 acc. to IEC 60751 ($\alpha = 0.00385$) Pt100 to JIS C1604-81 ($\alpha = 0.003916$)	-200 to 850 °C (-328 to 1562 °F) -200 to 250 °C (-328 to 482 °F) -200 to 250 °C (-238 to 482 °F) -200 to 649 °C (-328 to 1200 °F)	10 K (18 °F) 10 K (18 °F) 10 K (18 °F) 10 K (18 °F)
	Ni100 Ni500 Ni1000 acc. to DIN 43760 ($\alpha = 0.006180$)	-60 to 250 °C (-76 to 482 °F) -60 to 150 °C (-76 to 302 °F) -60 to 150 °C (-76 to 302 °F)	10 K (18 °F) 10 K (18 °F) 10 K (18 °F)
	<ul style="list-style-type: none"> ■ Connection type: 2-, 3- or 4-wire connection ■ Software compensation of cable resistance possible in the 2 wire system (0 to 30 Ω) ■ Sensor cable resistance max. 20 Ω per cable in the 3 and 4 wire system ■ Sensor current: ≤ 0.2 mA ■ Corrosion detection as per NAMUR NE 89 for Pt100 4-wire connection (optional for 'Advanced Diagnostic' version, see 'Product structure'). If corrosion detection is active, the response time is 2 s. 		
<i>Resistance transmitter</i>	Resistance Ω	10 to 400 Ω 10 to 2000 Ω	10 Ω 100 Ω
<i>Thermocouple (TC)</i>	B (PtRh30-PtRh6) C (W5Re-W26Re) ¹ D (W3Re-W25Re) ¹ E (NiCr-CuNi) J (Fe-CuNi) K (NiCr-Ni) L (Fe-CuNi) ² N (NiCrSi-NiSi) R (PtRh13-Pt) S (PtRh10-Pt) T (Cu-CuNi) U (Cu-CuNi) ² acc. to IEC 584 Part 1	0 to +1820 °C (32 to 3308 °F) 0 to +2320 °C (32 to 4208 °F) 0 to +2495 °C (32 to 4523 °F) -270 to +1000 °C (-454 to 1832 °F) -210 to +1200 °C (-346 to 2192 °F) -270 to +1372 °C (-454 to 2501 °F) -200 to +900 °C (-328 to 1652 °F) -270 to +1300 °C (-454 to 2372 °F) -50 to +1768 °C (-58 to 3214 °F) -50 to +1768 °C (-58 to 3214 °F) -270 to +400 °C (-454 to 752 °F) -200 to +600 °C (-328 to 1112 °F)	500 K (900 °F) 500 K (900 °F) 500 K (900 °F) 50 K (90 °F) 50 K (90 °F) 50 K (90 °F) 50 K (90 °F) 50 K (90 °F) 500 K (900 °F) 500 K (900 °F) 500 K (900 °F) 50 K (90 °F) 50 K (90 °F)
	<ul style="list-style-type: none"> ■ Cold junction: internal (Pt100) ■ Cold junction accuracy: ± 1 K 		
<i>Voltage transmitters</i>	Millivolt transmitter	-10 to 75 mV	5 mV

1) acc. to ASTM E988

2) acc. to DIN 43710

Output

Output signal	Analog 4 to 20 mA, 20 to 4 mA
Signal on alarm	<ul style="list-style-type: none"> ■ Underranging Linear drop to 3.8 mA ■ Overranging: Linear rise to 20.5 mA ■ Sensor break; sensor short-circuit (not for thermocouples TC): ≤ 3.6 mA or ≥ 21.0 mA <p> Note! Guaranteed values for setting "high alarm" (≥ 21 mA):</p> <ul style="list-style-type: none"> ■ Standard model: > 21.5 mA ■ Advanced diagnostic model: ≥ 22.5 mA
Load	max. $(V_{\text{Power supply}} - 11.5 \text{ V}) / 0.022 \text{ A}$ (Current output)
Linearization/transmission behaviour	Temperature linear, resistance linear, voltage linear
Filter	1st order digital filter: 0 to 100 s
Galvanic isolation	U = 2 kV AC (input/output)
Min. current consumption	≤ 3.5 mA
Current limit	≤ 23 mA
Switch on delay	4 s (during power up $I_a = 3.8 \text{ mA}$)

Power supply

Electrical connection

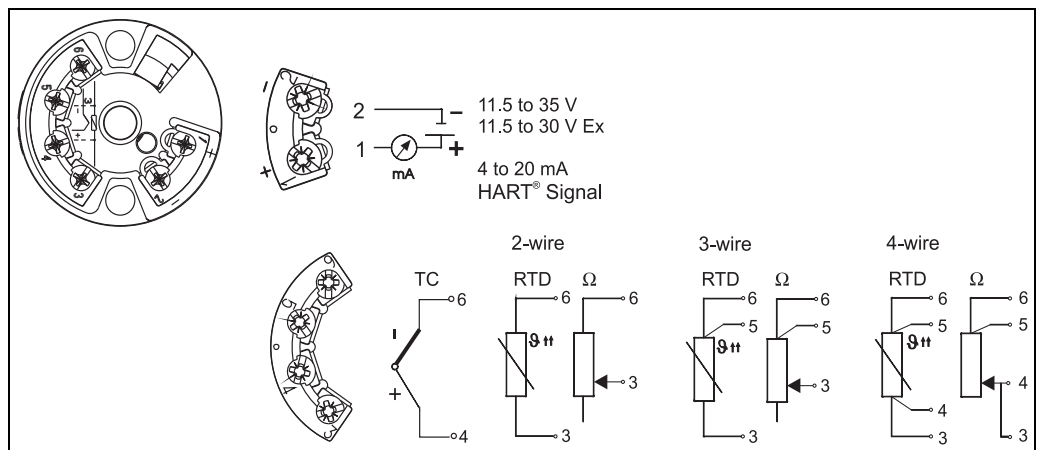

Head transmitter terminal connections

For the unit operation via HART® protocol (terminals 1 and 2) a minimum load resistance of 250 Ω is necessary in the signal circuit!

Supply voltage	$U_b = 11.5 \text{ to } 35 \text{ V}$, polarity protection
-----------------------	---

Undervoltage detection	Optional for 'Advanced Diagnostic' version. If the supply voltage is not sufficient to output the output signal corresponding to the measured temperature, a signal on alarm ≤ 3.6 mA is generated. After approx. 2 to 3 s, the system makes another attempt to output the signal corresponding to the temperature.
-------------------------------	---

Residual ripple	Allowable ripple $U_{ss} \leq 3$ V at $U_b \geq 13$ V, $f_{max.} = 1$ kHz
------------------------	---

Performance characteristics

Response time	1 s (TC), 1.5 s (RTD)
----------------------	-----------------------

Reference operating conditions	Calibration temperature: $+25$ °C (77 °F) ± 5 K (9 °F)
---------------------------------------	--

Maximum measured error



Note!

The accuracy data are typical values and correspond to a standard deviation of $\pm 3\sigma$ (normal distribution), i.e. 99.8% of all the measured values achieve the given values or better values.

	Type	Measurement accuracy ¹⁾
Resistance thermometer RTD	Pt100, Ni100 Pt500, Ni500 Pt1000, Ni1000	0.2 K or 0.08% 0.5 K or 0.20% 0.3 K or 0.12%
Thermocouple TC	K, J, T, E, L, U N, C, D R, S B	typ. 0.5 K or 0.08% typ. 1.0 K or 0.08% typ. 1.4 K or 0.08% typ. 2.0 K or 0.08%

	Measurement range	Measurement accuracy ¹⁾
Resistance transmitter (Ω)	10 to 400 Ω 10 to 2000 Ω	± 0.1 Ω or 0.08% ± 1.5 Ω or 0.12%
Voltage transmitters (mV)	-10 to 75 mV	± 20 μ V or 0.08%

1) % is related to the adjusted measurement range. The value to be applied is the greater.

Physical input range of the sensors	
10 to 400 Ω	Polynom RTD, Pt100, Ni100
10 to 2000 Ω	Pt500, Pt1000, Ni1000
-10 to 75 mV	Thermocouple type: C, D, E, J, K, L, N, U
-10 to 35 mV	Thermocouple type: B, R, S, T

Influence of supply voltage	$\leq \pm 0.01\%/V$ deviation from 24 V Percentages refer to the full scale value.
------------------------------------	---

Influence of ambient temperature (temperature drift)	Total temperature drift = input temperature drift + output temperature drift
---	--

Effect on the accuracy when ambient temperature changes by 1 K (1.8 °F):	
Input 10 to 400 Ω	typ. 0.0015% of measured value, min. 4 m Ω
Input 10 to 2000 Ω	typ. 0.0015% of measured value, min. 20 m Ω

Input -10 to 75 mV	typ. 0.005% of measured value, min. 1.2 μ V
Input -10 to 35 mV	typ. 0.005% of measured value, min. 0.6 μ V
Output 4 to 20 mA	typ. 0.005% of span

Typical sensitivity of resistance thermometers:

Pt: $0.00385 * R_{\text{nominal}}/K$	Ni: $0.00617 * R_{\text{nominal}}/K$
--------------------------------------	--------------------------------------

Example Pt100: $0.00385 * 100 \Omega/K = 0.385 \Omega/K$

Typical sensitivity of thermocouples:

B: 10 μ V/K	C: 20 μ V/K	D: 20 μ V/K	E: 75 μ V/K	J: 55 μ V/K	K: 40 μ V/K
L: 55 μ V/K	N: 35 μ V/K	R: 12 μ V/K	S: 12 μ V/K	T: 50 μ V/K	U: 60 μ V/K

Example for calculating measured error for ambient temperature drift:

Input temperature drift $\Delta\theta = 10 \text{ K (18 }^\circ\text{F)}$, Pt100, measuring range 0 to 100 $^\circ\text{C (32 to 212 }^\circ\text{F)}$

Maximum process temperature: 100 $^\circ\text{C (212 }^\circ\text{F)}$

Measured resistance value: 138.5 Ω (IEC 60751) at maximum process temperature

Typical temperature drift in Ω : $(0.0015\% \text{ of } 138.5 \Omega) * 10 = 0.02078 \Omega$

Conversion to Kelvin: $0.02078 \Omega / 0.385 \Omega/K = 0.05 \text{ K (0.09 }^\circ\text{F)}$

Influence of load	$\pm 0.02\%/100 \Omega$ Values refer to the full scale value
Long-term stability	$\leq 0.1 \text{ K/year}$ or $\leq 0.05\%/year$ Values under reference operating conditions. % refer to the set span. The highest value is valid.
Influence of cold junction	Pt100 DIN IEC 60751 Cl. B (internal cold junction with thermocouples TC)

Installation conditions

Installation instructions	<ul style="list-style-type: none"> ■ Installation angle: no limit ■ Installation area: Terminal head accord. to DIN 43 729 Form B; TAF10 field housing
----------------------------------	--

Environment conditions

Ambient temperature limits	-40 to +85 $^\circ\text{C (-40 to 185 }^\circ\text{F)}$ for Ex-area, see Ex-certificate
Storage temperature	-40 to +100 $^\circ\text{C (-40 to 212 }^\circ\text{F)}$
Climate class	According to IEC 60 654-1, class C
Condensation	Permitted
Degree of protection	IP 00, IP 66 installed

Shock and vibration resistance 4g / 2 to 150 Hz as per IEC 60 068-2-6

Electromagnetic compatibility (EMC) Interference immunity and interference emission as per IEC 61326 and NAMUR NE 21

Mechanical construction

Design, dimensions

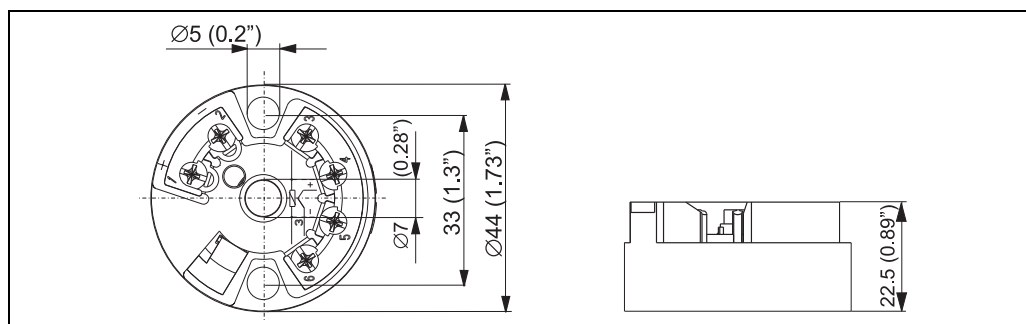

Dimensions of the head transmitter in mm (in)

Weight approx. 40 g (1.4 oz)

Material

- Housing: PC
- Potting: PUR

Terminals

- Cable up to max. 1.75 mm² (secure screws)
- or 1.5 mm² with wire end ferrules
- eyelets for easy connection of a HART[®]-handheld terminal with alligator clips

Human interface

Display elements No display elements are present directly on the temperature transmitter. The measured value display can be called up using the ReadWin[®] 2000 or FieldCare PC software.

Operating elements At the temperature transmitter no operating elements are available directly. The temperature transmitter will be configured by remote operation with the PC software ReadWin[®] 2000 or FieldCare.

Remote operation

Configuration
Hand operating module DXR275, DXR375 or PC with Commubox FXA191/FXA195 and operating software (ReadWin[®] 2000 or FieldCare).

Interface
PC interface Commubox FXA191 (RS232) or FXA195 (USB)

Configurable parameters
Sensor type and connection type, engineering units (°C/°F), measurement range, internal/external cold junction, compensation of wire resistance with 2-wire connection, failure mode, output signal (4 to 20/20 to 4 mA), digital filter (damping), offset, TAG + descriptor (8 + 16 characters), output simulation, customer specific linearization, min./max. process value indicator function

Certificates and approvals

CE-Mark	The device meets the legal requirements of the EC directives. Endress+Hauser confirms that the device has been successfully tested by applying the CE mark.
Hazardous area approvals	For further details on the available Ex versions (ATEX, CSA, FM, etc.), please contact your nearest Endress+Hauser sales organisation. All relevant data for hazardous areas can be found in separate Ex documentation. If required, please request copies from us or your Endress+Hauser sales organisation.
GL	Ship building approval (Germanischer Lloyd)
UL	Recognized component to UL 3111-1
Other standards and guidelines	<ul style="list-style-type: none">■ IEC 60529: Degree of protection provided by housing (IP-Code)■ IEC 61010: Safety requirements for electrical measurement, control and laboratory use.■ IEC 61326: Electromagnetic compatibility (EMC requirements)■ NAMUR Standards working group for measurement and control technology in the chemical industry. (www.namur.de)
CSA GP	CSA General Purpose

Ordering information

Questionnaire

Questionnaire Endress+Hauser iTEMP temperature transmitter Customer specific setup / Kundenspezifische Einstellung	
Standard setup / Standardeinstellung	
Sensor	TC <input type="checkbox"/> B <input type="checkbox"/> C <input type="checkbox"/> D <input type="checkbox"/> E <input type="checkbox"/> J <input type="checkbox"/> K <input type="checkbox"/> L <input type="checkbox"/> N <input type="checkbox"/> R <input type="checkbox"/> S <input type="checkbox"/> T <input type="checkbox"/> U
	RTD <input type="checkbox"/> Pt100 <input type="checkbox"/> Pt500 <input type="checkbox"/> Pt1000 <input type="checkbox"/> Ni100 <input type="checkbox"/> Ni500 <input type="checkbox"/> Ni1000
	<input type="checkbox"/> 2 wire <input type="checkbox"/> 3 wire <input type="checkbox"/> 4 wire
Unit / Einheit	<input type="checkbox"/> °C <input type="checkbox"/> °F
Range / Messbereich (not / nicht PROFIBUS-PA)	Low scale Anfang <input type="text"/> <input type="text"/> <input type="text"/> <input type="text"/> <input type="text"/> <input type="text"/> <input type="text"/> <input type="text"/> . <input type="text"/>
	High scale Ende <input type="text"/> <input type="text"/> <input type="text"/> <input type="text"/> <input type="text"/> <input type="text"/> <input type="text"/> <input type="text"/> . <input type="text"/>
	Bitte beachten! Messbereich und min. Spanne (s. Techn. Daten)
	Note! Range and min. span (s. Techn. data)
Bus address / Busadresse (only / nur PROFIBUS-PA)	<input type="text"/> <input type="text"/> <input type="text"/> [0...126]
Expanded setup / Erweiterte Einstellung	
Reference junction / Vergleichsstelle	<input type="checkbox"/> intern <input type="checkbox"/> extern (only / nur TC) <input type="text"/> <input type="text"/> <input type="text"/> [0...80°C; 32...176°F]
Compensation wire resistance / Kompensation Leitungswiderstand	<input type="text"/> <input type="text"/> [0...20 Ohm] (only / nur RTD 2 wire) <input type="text"/> <input type="text"/> [0...30 Ohm] (only / nur HART, PA RTD 2 wire)
Failure mode / Fehlerverhalten	<input type="checkbox"/> ≤ 3.6 mA <input type="checkbox"/> ≥ 21.0 mA (not / nicht PROFIBUS-PA)
Output / Ausgang	<input type="checkbox"/> 4...20 mA <input type="checkbox"/> 20...4 mA (not / nicht PROFIBUS-PA)
Filter	<input type="text"/> <input type="text"/> <input type="text"/> [0, 1, 2,..., 8s] (only / nur PCP) <input type="text"/> <input type="text"/> <input type="text"/> [0, 1, 2,..., 100s]
Offset	<input type="text"/> <input type="text"/> <input type="text"/> . <input type="text"/> [-9.9... 0...+9.9K]
TAG	<input type="text"/> <input type="text"/> <input type="text"/> <input type="text"/> <input type="text"/> <input type="text"/> <input type="text"/> <input type="text"/> <input type="text"/> <input type="text"/> <input type="text"/> <input type="text"/>
PCP	<input type="text"/> <input type="text"/> <input type="text"/> <input type="text"/> <input type="text"/> <input type="text"/> <input type="text"/> <input type="text"/> <input type="text"/> <input type="text"/> <input type="text"/> <input type="text"/>
HART	(HART: 8 char. TAG + 16 char. Descriptor , PROFIBUS-PA: 32 char.)
PROFIBUS-PA	<input type="text"/> <input type="text"/> <input type="text"/> <input type="text"/> <input type="text"/> <input type="text"/> <input type="text"/> <input type="text"/> <input type="text"/> <input type="text"/> <input type="text"/> <input type="text"/> <input type="text"/> <input type="text"/> <input type="text"/> <input type="text"/>
Endress+Hauser  People for Process Automation	

Product structure

This information provides an overview of the order options available. The information is not exhaustive, however, and may not be fully up to date. **More detailed** information is available from your local Endress+Hauser representative.

Head transmitter iTEMP® HART® TMT182

Temperature transmitter with HART®-Protocol for RTD's, TC's, Ohm and mV, analog output 4 to 20 mA, SIL2, 2-wire-technology, galvanic isolation, fail. mode to NAMUR NE 43, for mounting in Form B head to DIN 43729, UL recognized component, ship building approval GL (Germanischer Lloyd)

Approval	
A	Non-hazardous area
B	ATEX II1G EEx ia IIC T4/T5/T6
C	FM IS, Class I, Div. 1+2, Group A, B, C, D
D	CSA IS, Class I, Div. 1+2, Group A, B, C, D
E	ATEX II3G Ex nA IIC T4/T5/T6
F	ATEX II3D
G	ATEX II1G EEx ia IIC T6, II3D
H	ATEX II3G Ex nA IIC T4/T5/T6, II3D
I	FM+CSA IS, NI, Class I, Div. 1+2, Group A, B, C, D
J	CSA General Purpose
K	IECEx Ex ia IIC T6/T5/T4
L	TIIS Ex ia IIC T4
M	TIIS Ex ia IIC T6
1	NEPSI Ex ia IIC T4...T6
2	NEPSI Ex nA II T4...T6

Configuration connection	
A	Factory setup Pt100 3-wire 0...100 °C
1	Thermocouple TC
2	RTD 2-wire
3	RTD 3-wire
4	RTD 4-wire

Configuration sensor type	
A	Factory setup Pt100 3-wire 0...100 °C
1	Pt100 -200 °C to 850 °C (-328 to 1562 °F) min. sp. 10 K, acc. to IEC 751 (a = 0.00385)
2	Ni100 -60 °C to 250 °C (-76 to 482 °F) min. sp. 10 K
3	Pt500 -200 °C to 250 °C (-328 to 482 °F) min. sp. 10 K
4	Ni500 -60 °C to 150 °C (-76 to 302 °F) min. sp. 10 K
5	Pt1000 -200 °C to 250 °C (-328 to 482 °F) min. sp. 10 K
6	Ni1000 -60 °C to 150 °C (-76 to 302 °F) min. sp. 10 K
7	Resistance transmitter 10...400 Ohm, min. span 10 Ohm
8	Resistance transmitter 10...2000 Ohm, min. span 100 Ohm
B	Typ B 400 °C to 1820 °C (752 to 3308 °F) min. sp. 500 K
C	Typ C 500 °C to 2320 °C (932 to 4208 °F) min. sp. 500 K
D	Typ D 500 °C to 2495 °C (932 to 4523 °F) min. sp. 500 K
E	Typ E -270 °C to 1000 °C (-454 to 1832 °F) min. sp. 50 K
J	Typ J -210 °C to 1200 °C (-346 to 2192 °F) min. sp. 50 K
K	Typ K -270 °C to 1372 °C (-454 to 2501 °F) min. sp. 50 K
L	Typ L -200 °C to 900 °C (-328 to 1652 °F) min. sp. 50 K
N	Typ N -100 °C to 1300 °C (-148 to 2372 °F) min. sp. 50 K
R	Typ R -50 °C to 1768 °C (-58 to 3214 °F) min. sp. 500 K
S	Typ S -50 °C to 1768 °C (-58 to 3214 °F) min. sp. 500 K
T	Typ T -270 °C to 400 °C (-454 to 752 °F) min. sp. 50 K
U	Typ U -200 °C to 600 °C (-328 to 1112 °F) min. sp. 50 K
V	Voltage transmitter -10...75 mV, min. span 5 mV
W	Pt100 -200 °C to 649 °C (-328 to 1200 °F) min. sp. 10 K, acc. to JIS C1604-81 (a = 0.003916)

Configuration	
A	Factory setup Pt100 3-wire 0...100 °C)
B	Measuring range, see additional specification
C	TC configuration range, see questionnaire
D	RTD configuration range, see questionnaire

Additional option	
A	Standard - DIN mounting set
B	Works calibration certificate 6-point, DIN mounting set
C	Diagnostic, advanced, DIN mounting set
K	US - M4 mounting screws
L	Diagnostic, advanced, US - M4 mounting screws

TMT182-					← Order code (complete)
----------------	--	--	--	--	--------------------------------

Accessories

- Commubox FXA191 (RS232) or FXA195 (USB)
Order code: FXA191-... or FXA195-...
- PC-operating software: ReadWin® 2000 or FieldCare
ReadWin® 2000 can be downloaded free of charge from the internet from the following address:
www.endress.com/readwin
- Hand operating module 'HART® Communicator DXR375', **Order code:** DXR375-...
- DIN rail clip according to IEC 60715 (TH35) for head transmitter mounting
Order code: 51000856
- Field housing TAF10 for Endress+Hauser head transmitter, aluminum, IP 66,
dimensions W x H x D: 100 x 100 x 60 mm (3.94" x 3.94" x 2.36")
Order code: TAF10-...

Documentation

- Operating short manual iTEMP® HART® TMT182 (KA142R/09/a3)
- Additional documentation for use in explosion-hazardous areas:
 - ATEX II1G: XA006R/09/a3
 - ATEX II3G: XA011R/09/a3
 - ATEX II3D: XA027R/09/a3
- Operating short manual TAF10 Field housing (KA093R/09/a2)
- Functional safety manual TMT182 (SD006R/09/en)

Instruments International

Endress+Hauser
Instruments International AG
Kaegenstrasse 2
4153 Reinach
Switzerland

Tel. +41 61 715 81 00
Fax +41 61 715 25 00
www.endress.com
info@ii.endress.com

Endress+Hauser 
People for Process Automation